

## CUTTING HD Ø1.5" - f5.0"/7.5" - SATURN III P/N: 030008

### FEATURES

- 1.4"/35mm Clear Aperture
- High Pressure Coaxial Assist Gas
- Vernier Adjustable Focus Control
- Lens Cartridge System
- Orthogonal Lens Centering
- Indirect Lens Cooling
- Modular Components
- Aluminum Construction
- No Special Tools Required

### SPECIFICATIONS

- Lens Diameter: Ø1.5"/38.1mm
- Focal Length: 5.0"/7.5"
- Assist Gas Port: 1/8 NPT
- Max Assist Gas: 500psi/34bar

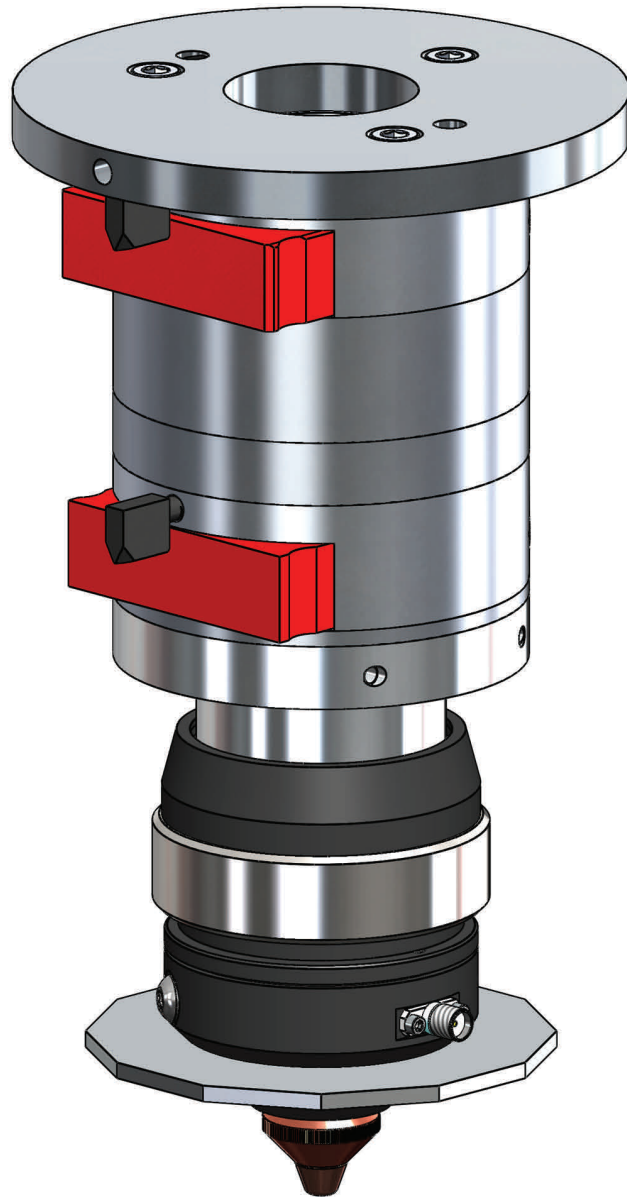

American Laser Enterprises, LLC.  
PO Box 309  
Novi, MI 48376  
Phone: 248-449-3714  
Fax: 248-449-7631  
Email: [info@a-l-e.net](mailto:info@a-l-e.net)  
Web: [a-l-e.net](http://a-l-e.net)

***"A Cut Above The Rest"***